



DBE2/Mk5C Frequency Selection

Arthur Niell

MIT Haystack Observatory

Observing Frequency Bands

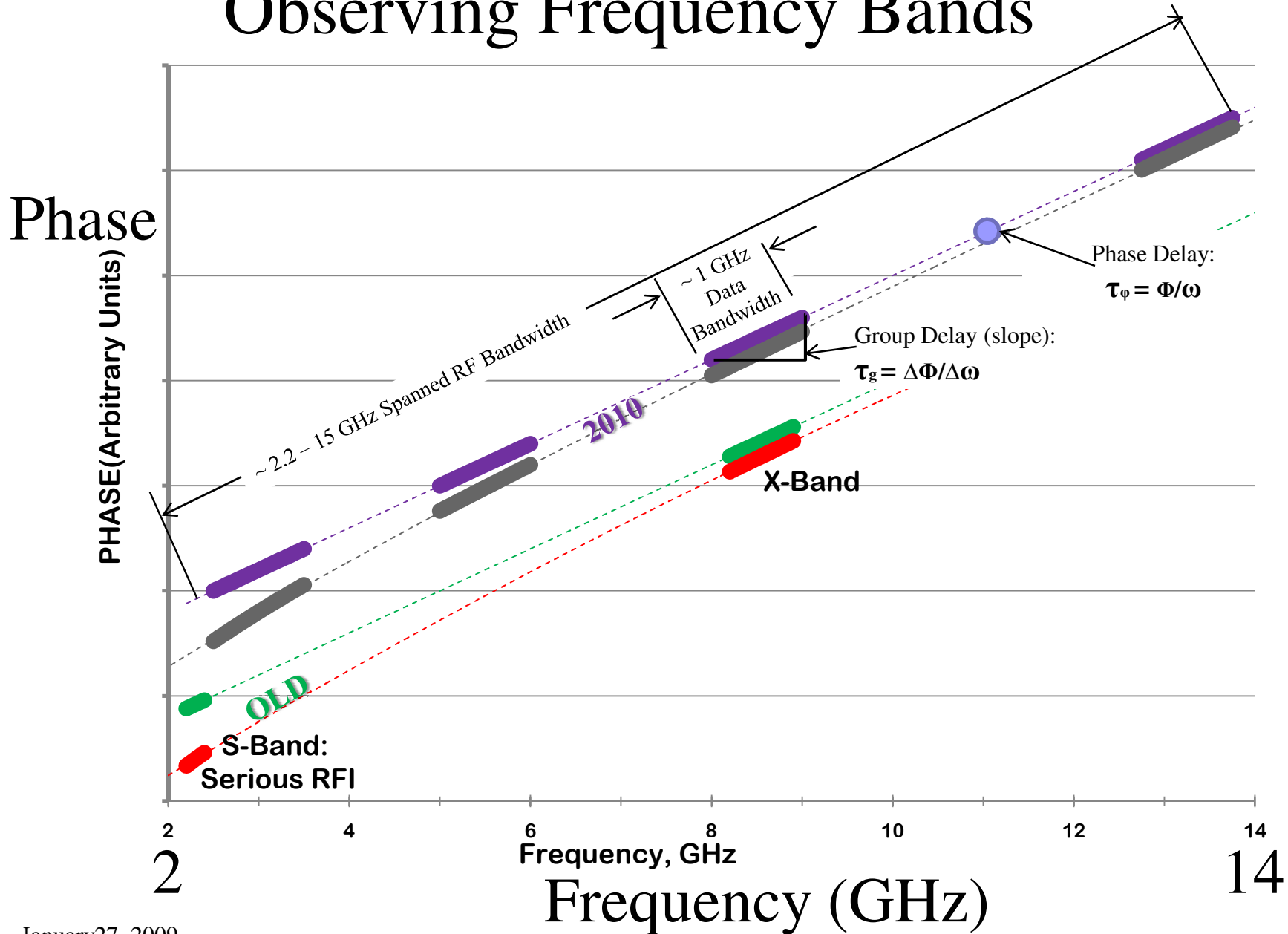

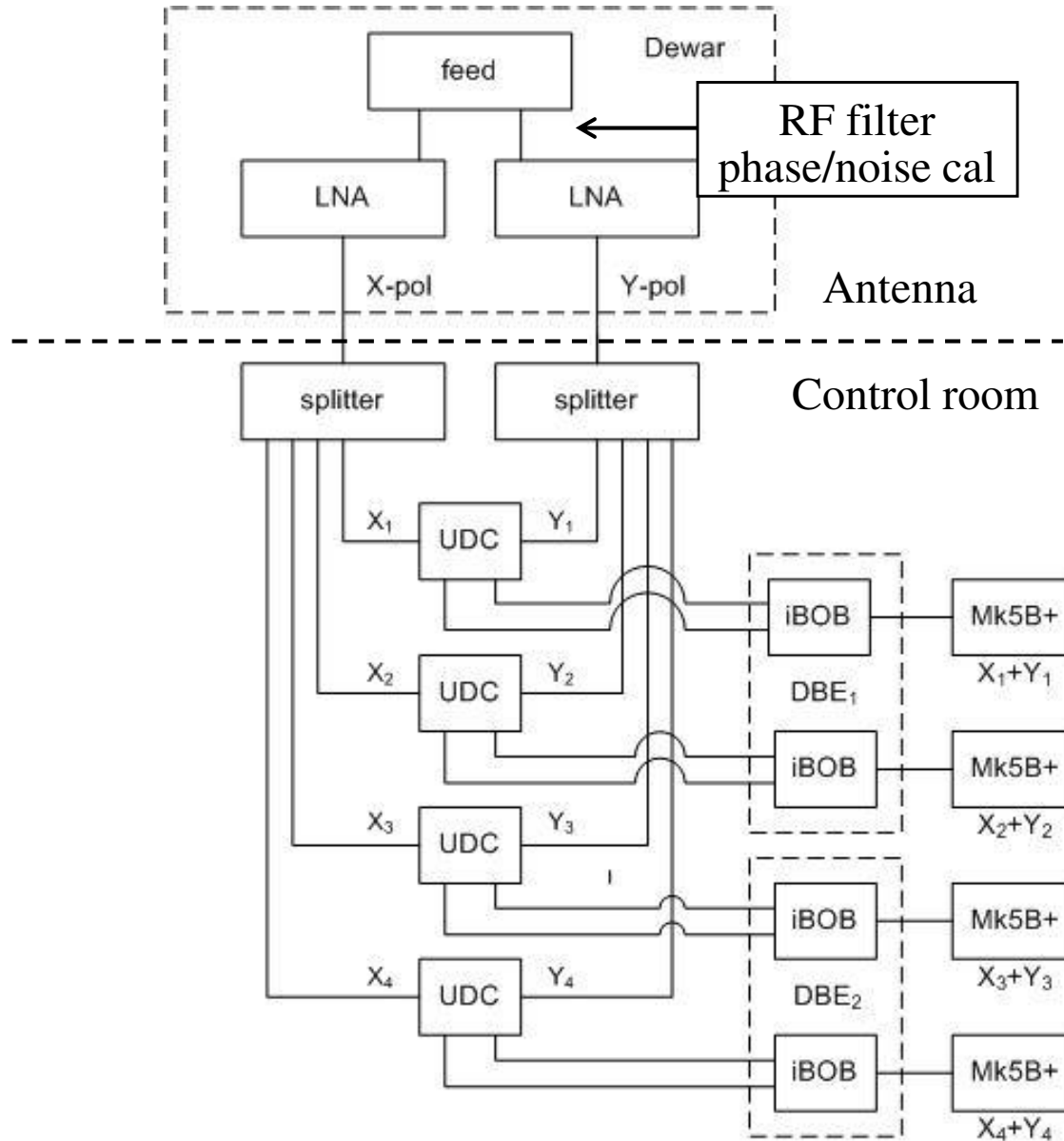

Feed and LNAs cooled to ~20K

Both senses of linear polarization used

Odd channels from each pol'n for one band output to each Mk5B+.

2 gigabits/sec recorded on each Mk5B+.

Total data rate: 8 gbps



Frequency Selection

- 512 MHz channels (not 1 GHz as Bill described)
 - 2 Gbps if fully recorded
 - (4 bands) times (2 polarizations) → 8 Mk5B+s or 4 Mk5Cs
- Frequency selection
 - Record only half of the data to reduce number of recorders
 - Retain only odd channels from PFB for simplicity
 - In the future use minimum redundancy sequence to improve delay resolution
 - In future the channels should be selectable at setup

Frequency Selection: Output from PFB

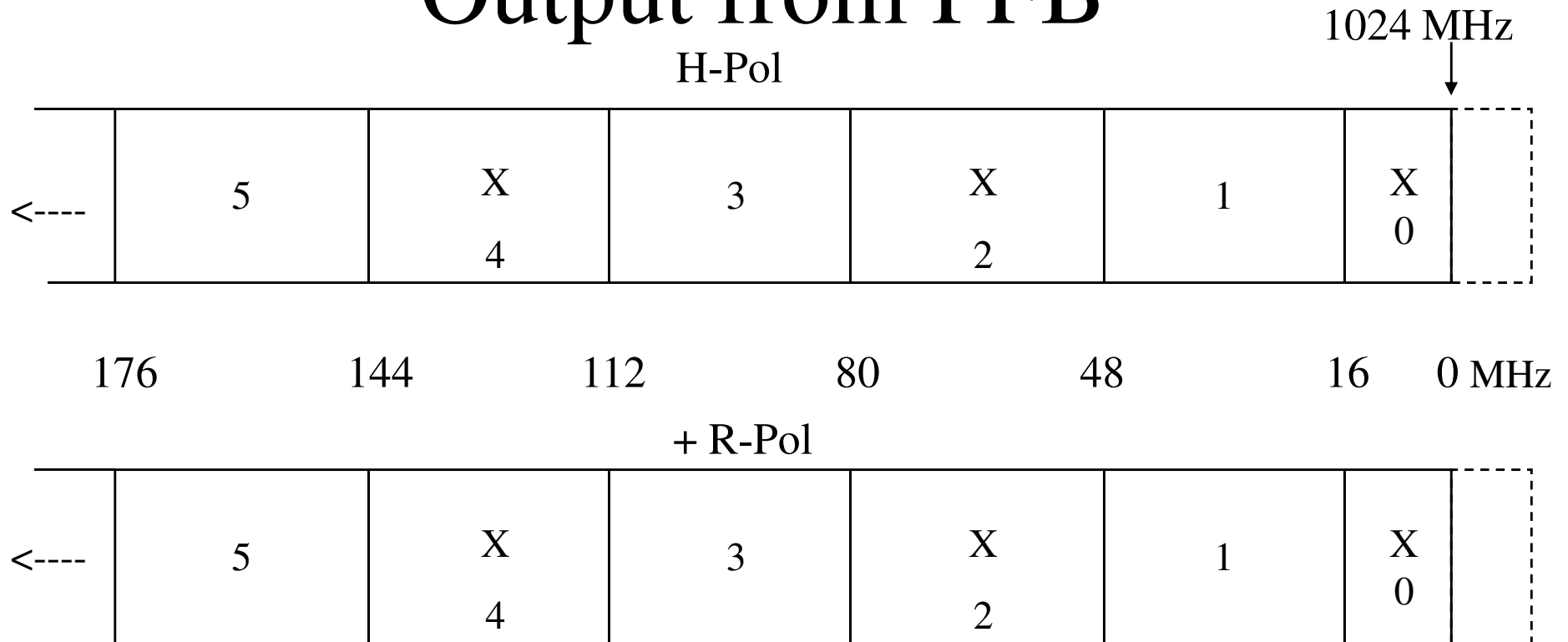

Write out 16 channels (512 MHz) at 2048 Mbps

H1 V1 H3 V3 H5 V5 H7 V7 ... H15 V15

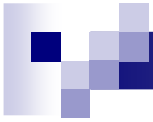



Recent Results

- Westford focus setting measurement
- Test sessions
 - Six hours with four bands identical frequencies
 - Five hours with bands contiguous -
 - Five hours on 4C39.25 polarization test

Westford focus measurement

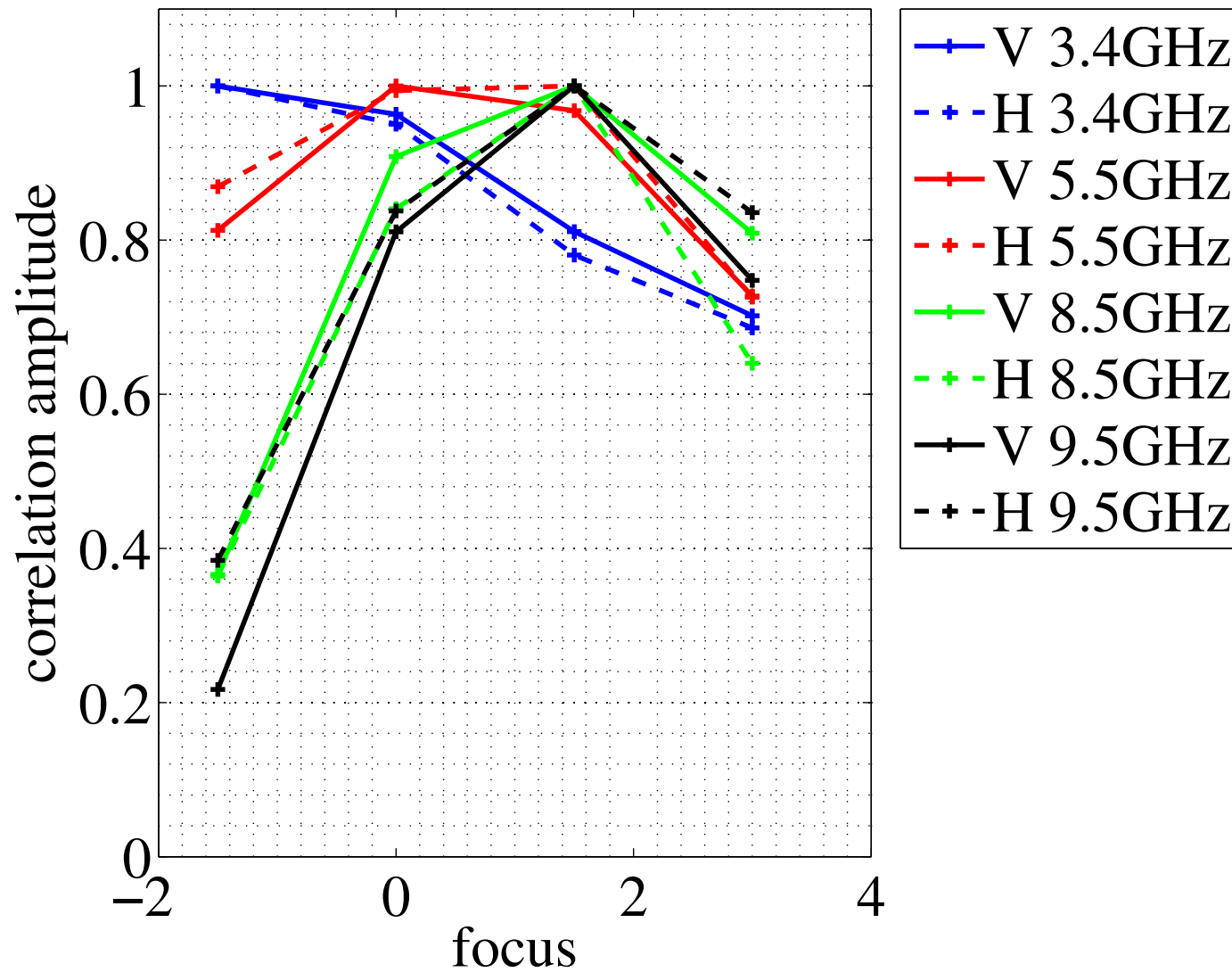



Polarization session

- Frequency coverage
 - 512 MHz bands
 - 3.5 GHz, 5.5 GHz, 7.5 GHz, and 8.0 GHz
- Source 4C39.25
 - Passes south of Westford and north of MV-3
 - Differential parallactic angle: $+6^\circ$ to $+279^\circ$
- Signal chains identical at both antennas
- All operations conducted from Haystack (except MV-3 antenna pointing)



Results

- Expected SNR ~250

- BW = 256 MHz

- Integration time = 570s

- Correlated flux density = 10Jy

- SEFDs = 3000Jy/100,000JY

- Observed SNR (max)

2009-040 freq (GHz)	3.5	5.5	7.5	8.0
	140	200	120	120

Parallactic Angle Differences

4C39.25 Wfrd-MV3

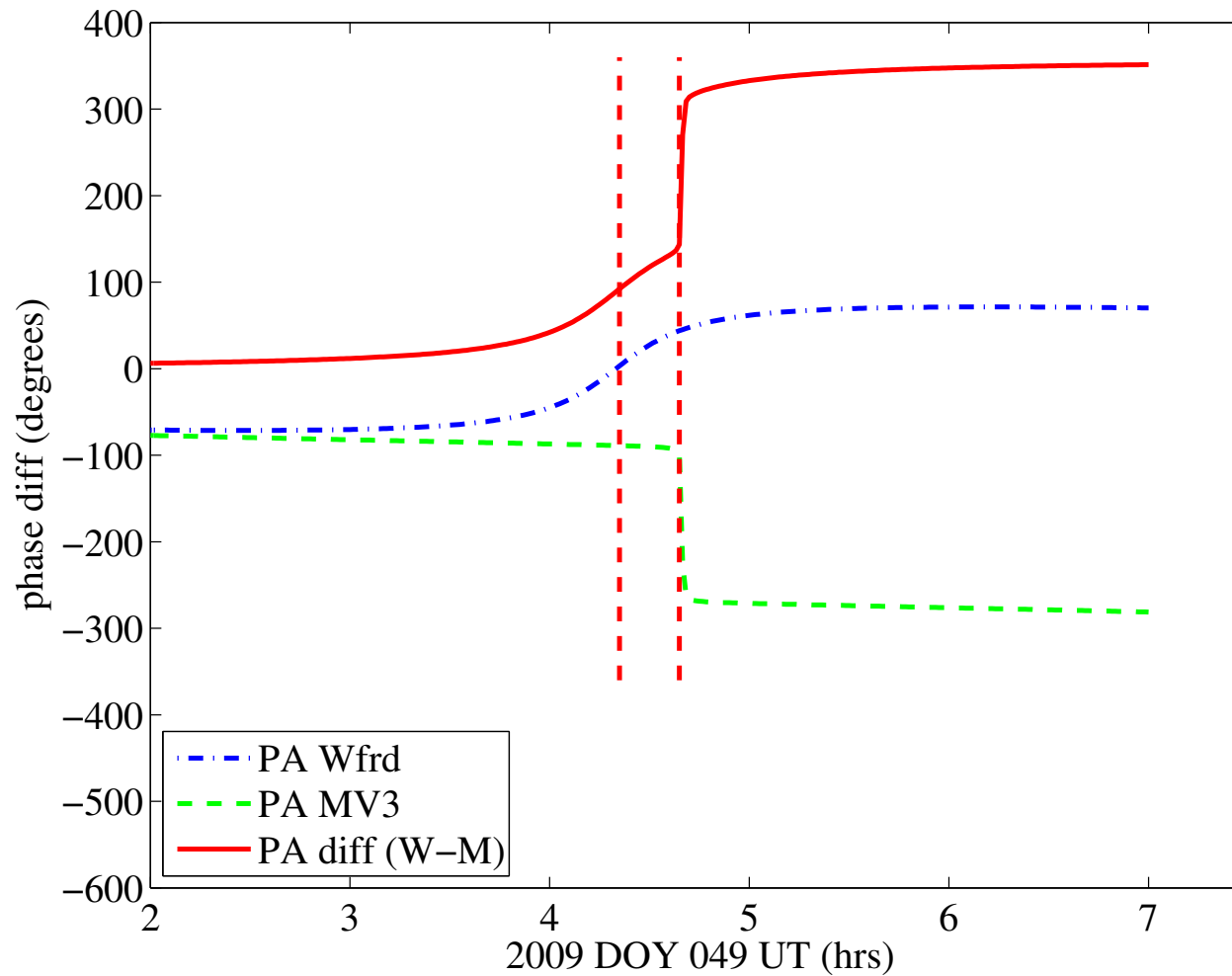

Polarization test

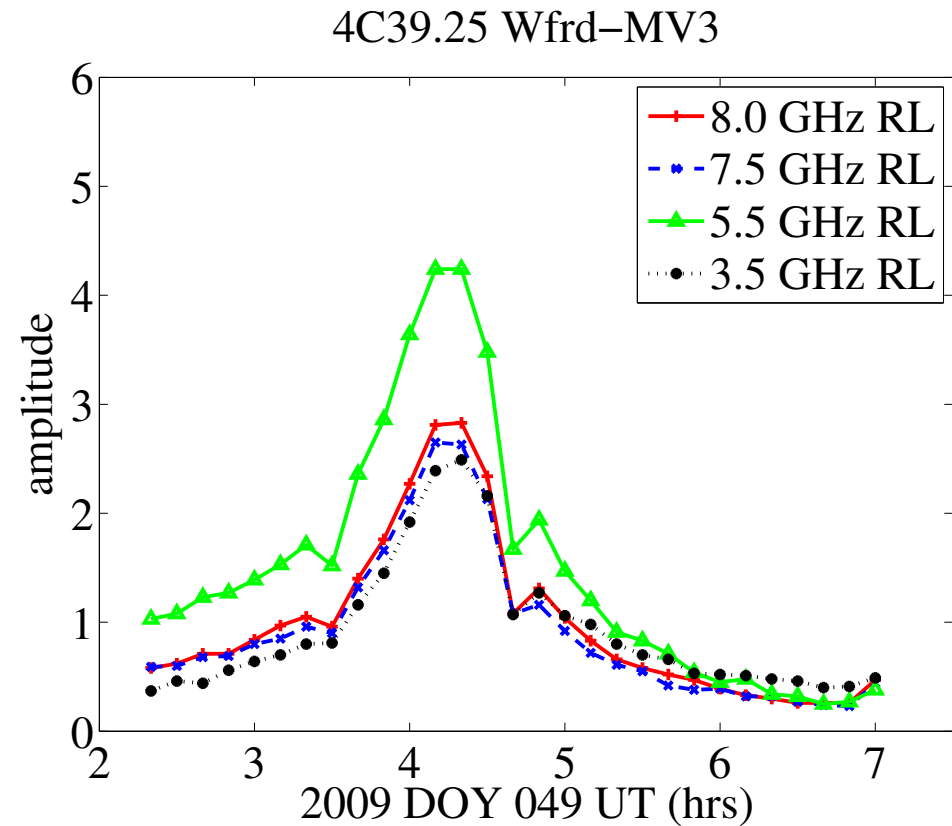
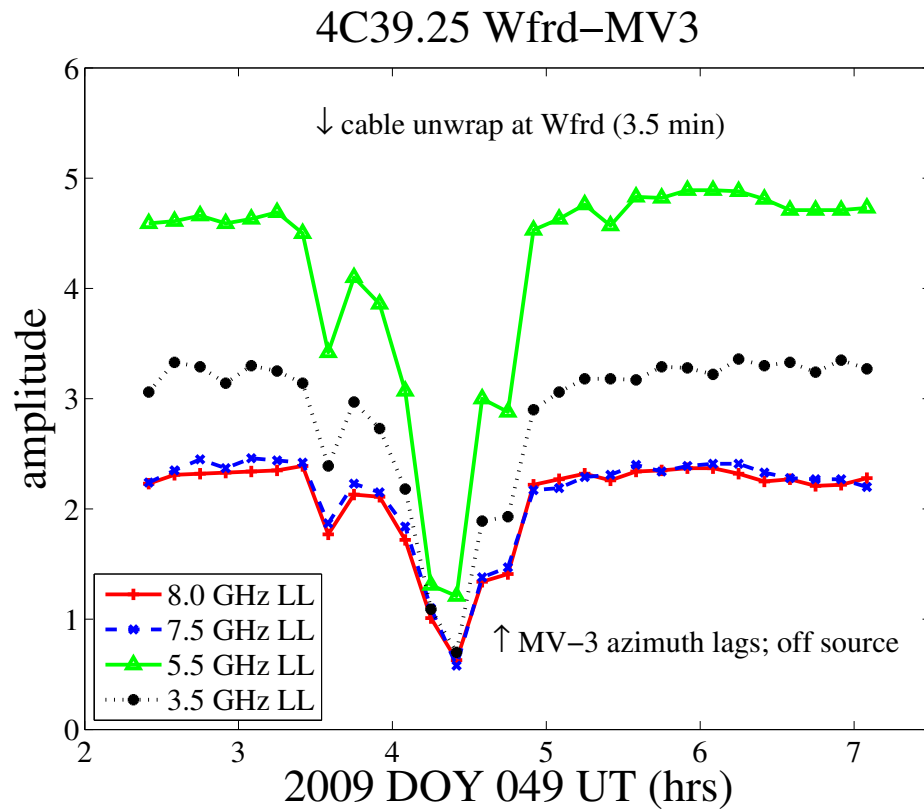

Polarization test

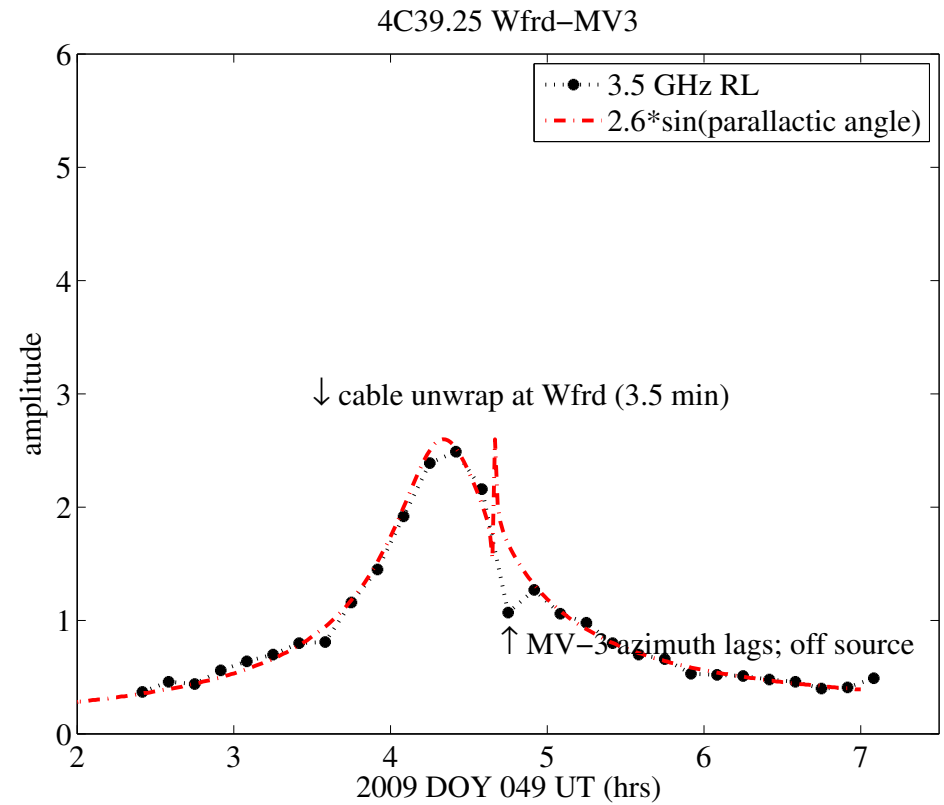
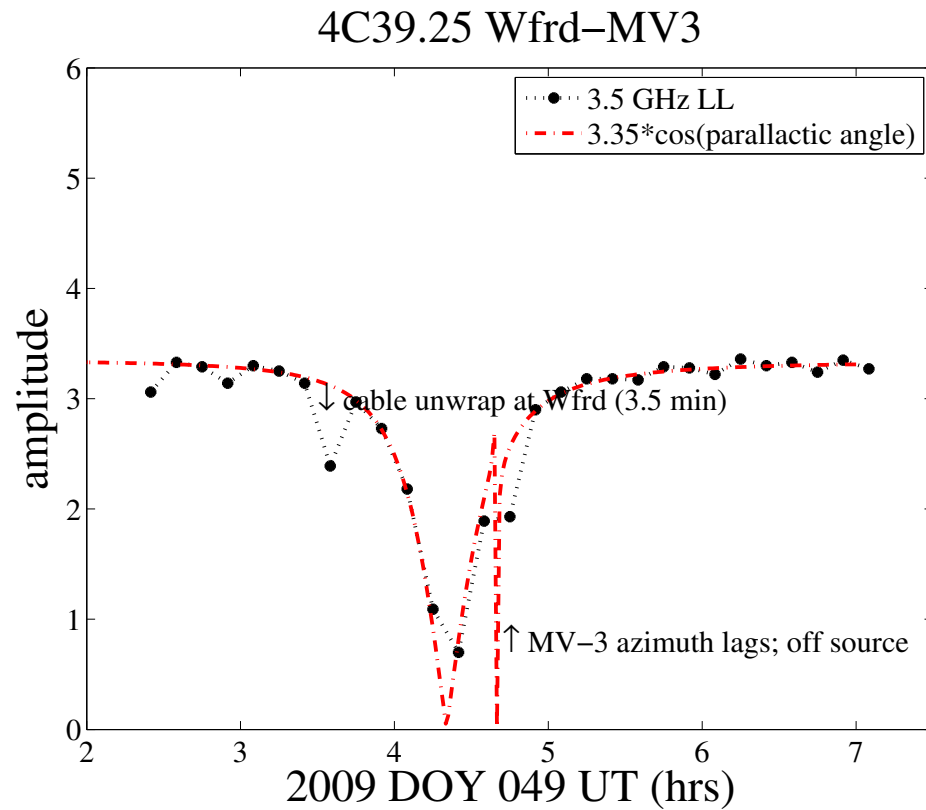

Polarization Phase Differences

(no phase cal applied)

4C39.25 Wfrd-MV3

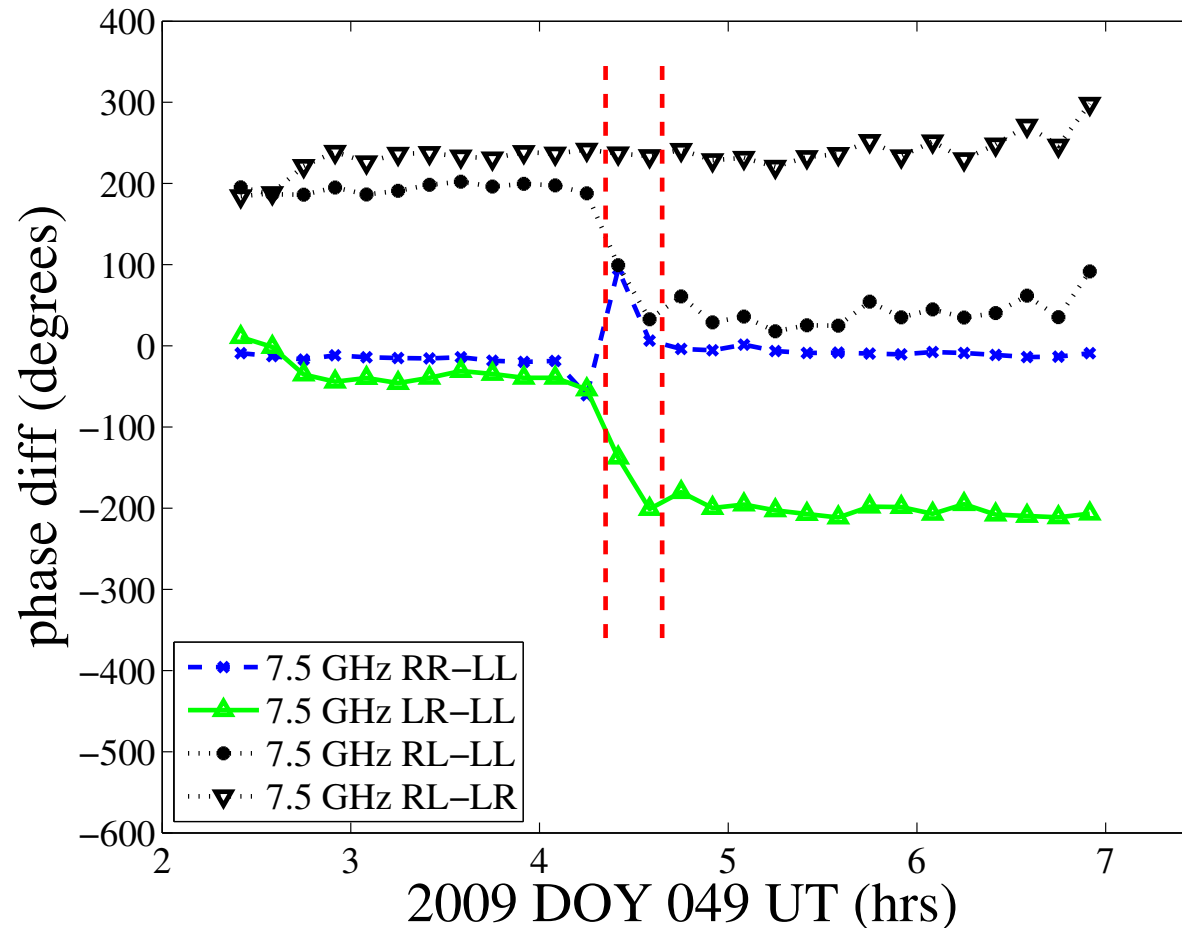

Polarization test (no phase cal applied)

4C39.25 Wfrd-MV3

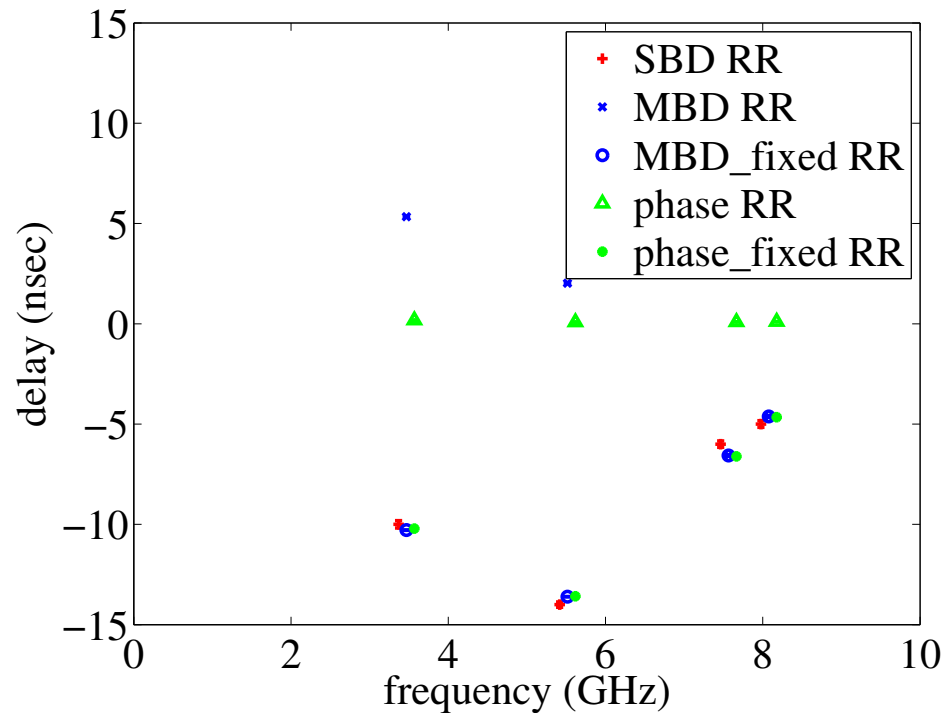

4C39.25 Wfrd-MV3

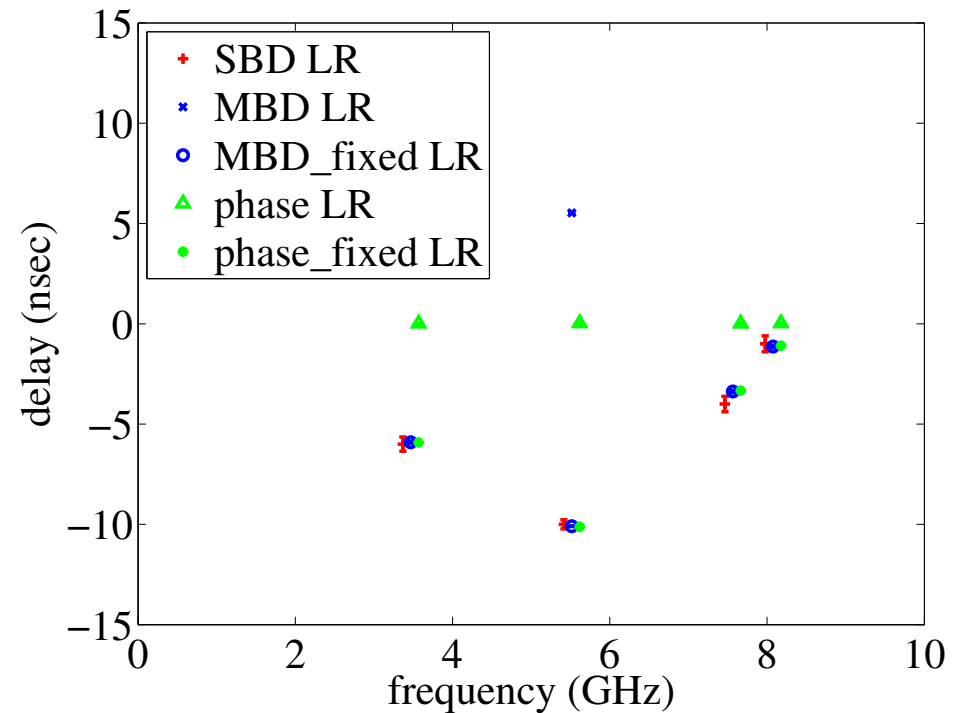

Polarization test (no phase cal applied)

4C39.25 Wfrd-MV3

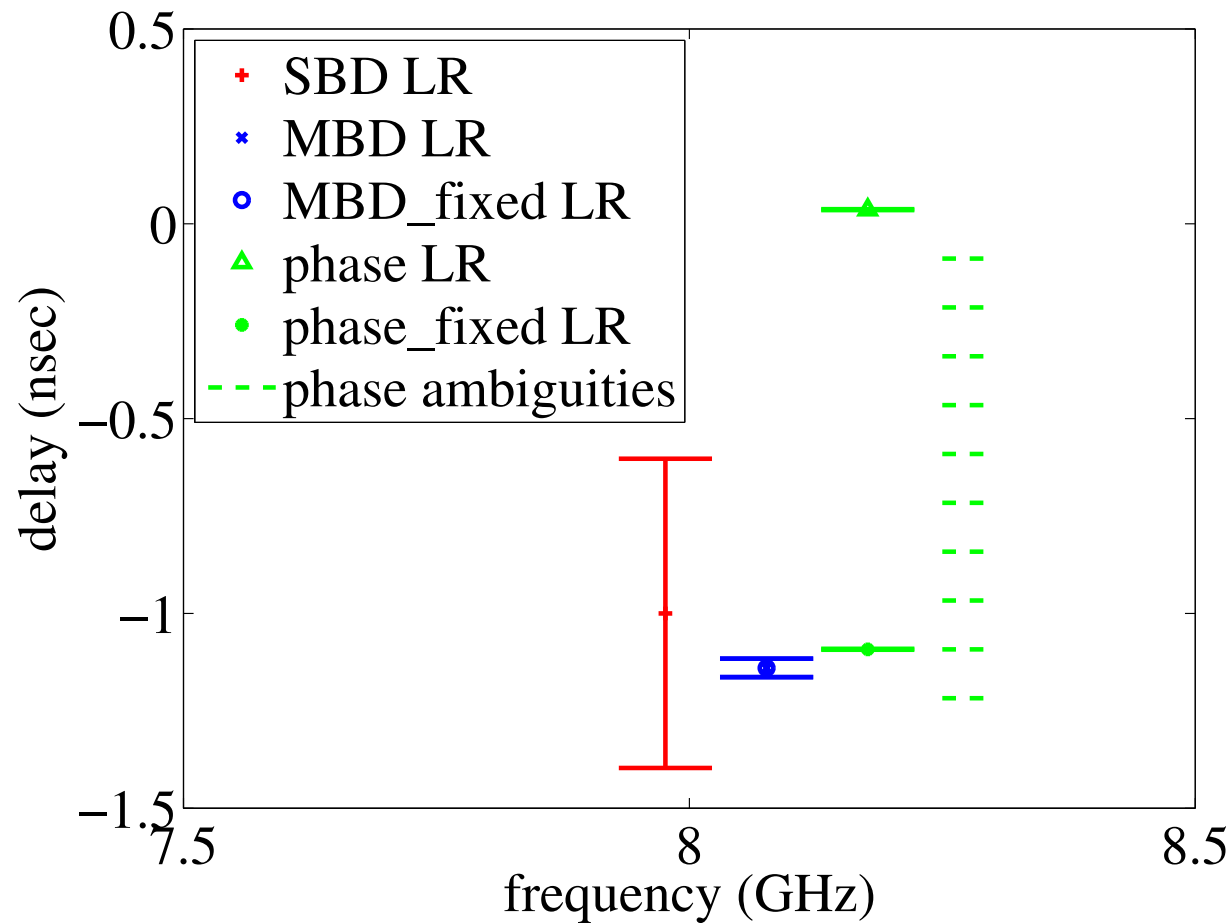



Proof of Concept System Status

	<u>Current</u>	<u>Next</u>
■ Feed	Lindgren	Eleven?
■ RF filter	>3.1 GHz	≥ 2.2 GHz
■ Phase cal	S/X pcal	“digital” pcal
■ DBE	DBE1(iBOB)	DBE2(ROACH)
■ Recorder	Mk5B+	Mk5C
■ Correlator	Mk4 (hardware)	Software (DiFX)

